



INSTALLATION



INSTALLATION

1) STARTS AND STOPS THE PUMP AUTOMATICALLY WHEN THE TAPS ARE OPENED AND CLOSED. PROTECTS AGAINST DRY OPERATION AND PUMP BLOCKAGE IN CASE OF PROLONGED NON-USE.

2) SAFETY INFORMATION



Installation reserved to specialised professionals



Disconnect the electrical power supply before all works!

3) INSTALLATION WITH SUBMERSIBLE OR EXTERNAL PUMP

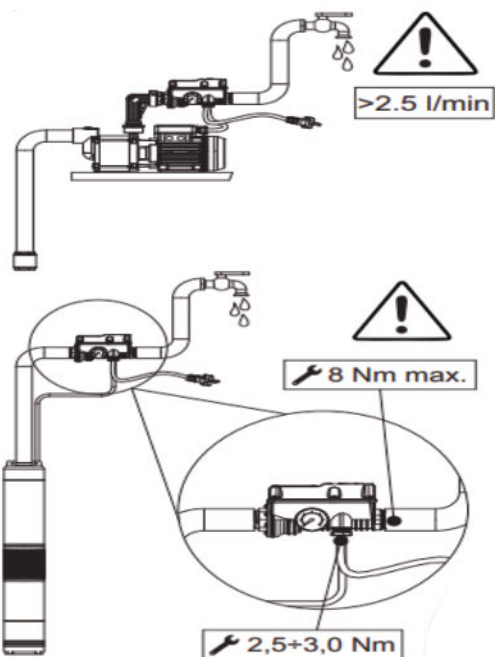

4) ALLOWED INSTALLATION POSITIONS



5) INSTALLATION WITH BYPASS FOR HIGH FLOW RATES

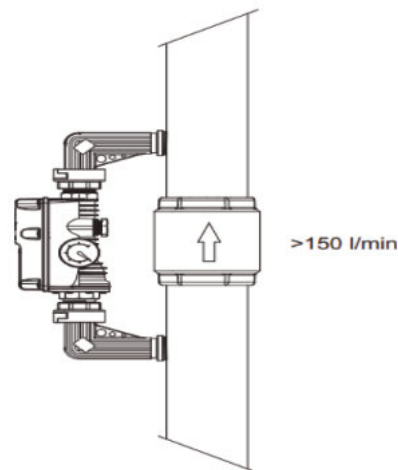

6) DO NOT INSTALL IN TRAPS

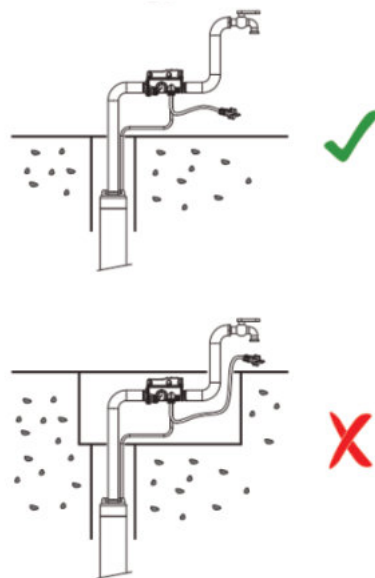

7) ALLOWED CHECK-VALVE POSITIONS

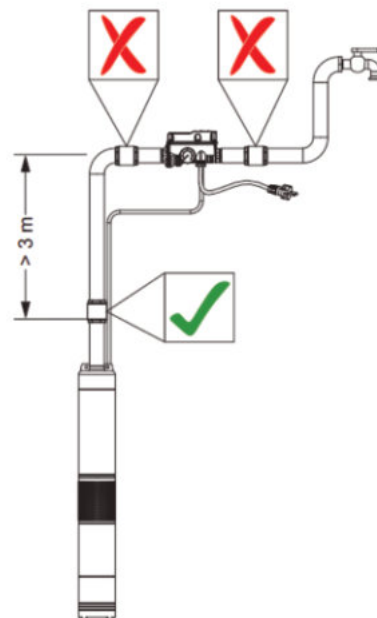

INSTALLATION

8) SUCTION FILTER RECOMMENDED

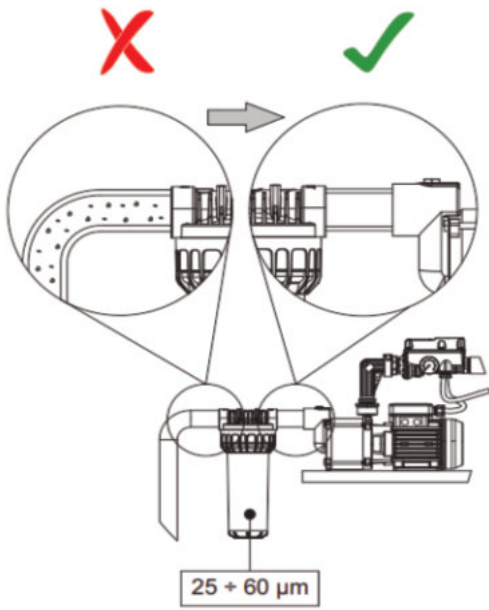

9) USE ONLY WITH WATER, MAX SALINITY 0.05%

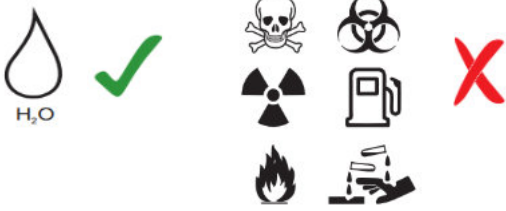

10) ELECTRICAL CONNECTION AND PROVISIONS FOR CABLES

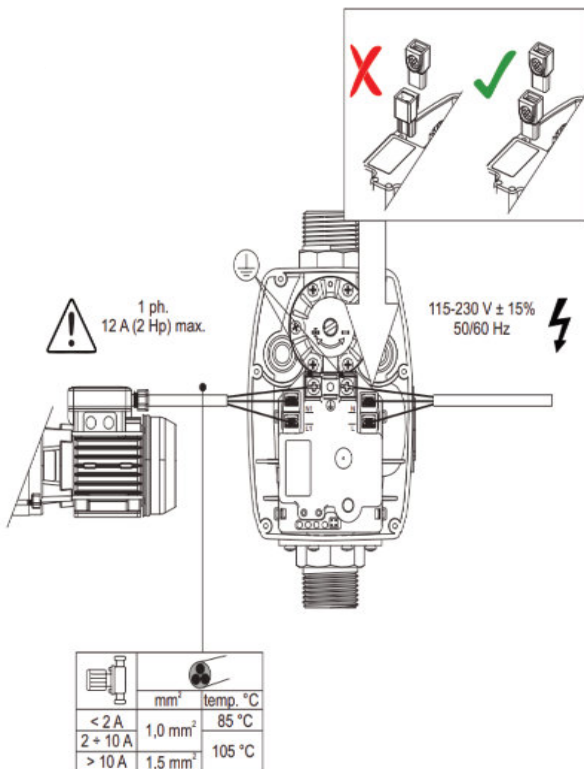

11) CONNECTION TO THREE-PHASE PUMP THROUGH RELAY

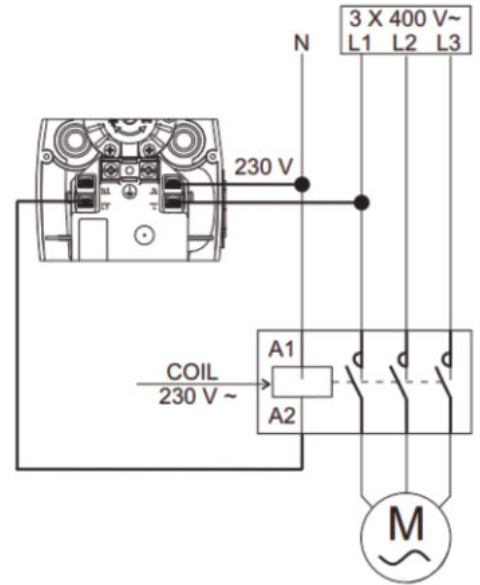

12) DO NOT INSTALL ANY ELECTRICAL DEVICES BETWEEN THE CONTROLLER AND THE PUMP (FLOAT, ETC.)

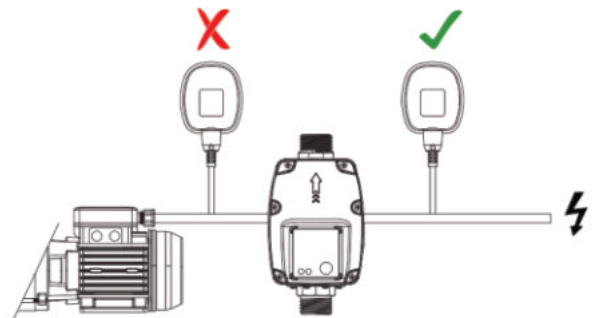

13) INCREASE THE STARTING PRESSURE IF THE SYSTEM EXCEEDS 15 METRES (MAXIMUM 3.5 BAR = 35 METRES)

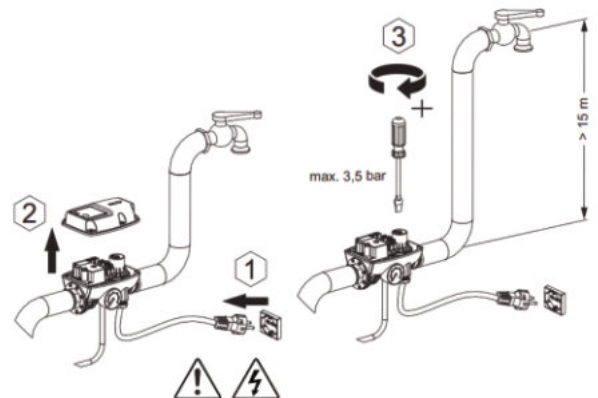

INSTALLATION

- 14) THE MAXIMUM PRESSURE IS NOT ADJUSTABLE !!

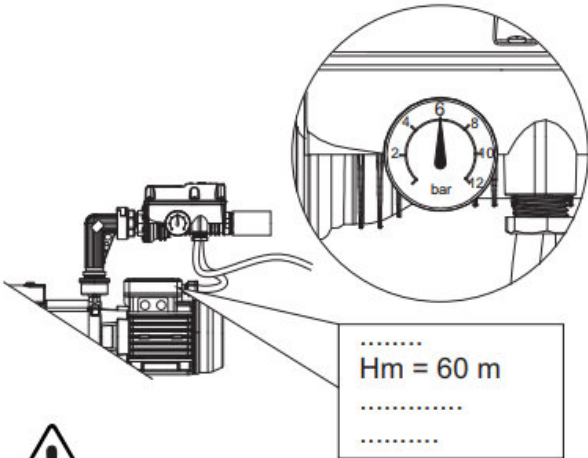

The maximum pressure corresponds to the pump head

- 15) DECOMMISSIONING - PERIODS OF NON-USE

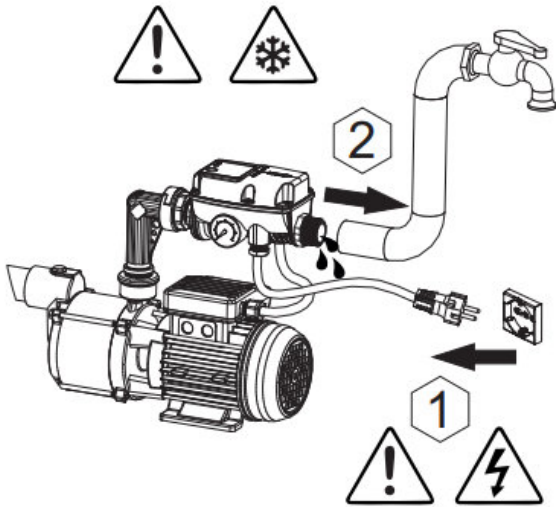

- 16) STOP DUE TO LACK OF WATER, MANUAL AUTOMATIC RESET

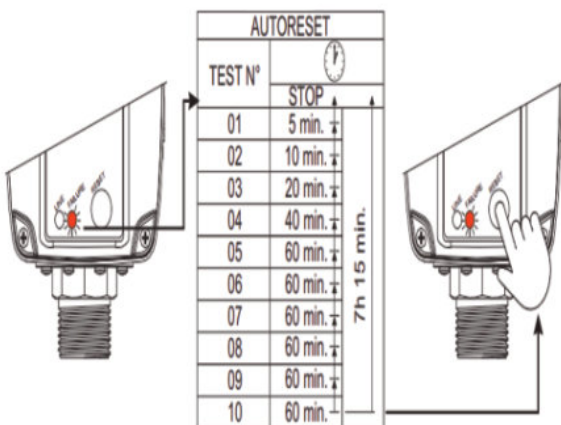

Check that the pump is not blocked

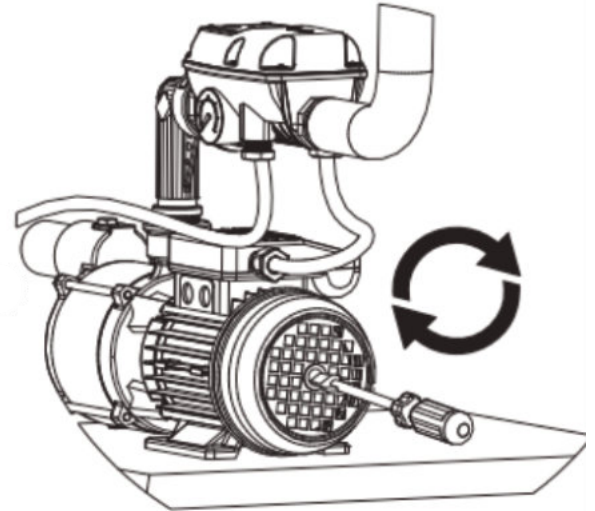

- 17) REMOVE JUMPER "A" TO DISABLE THE AUTOMATIC RESET AND JUMPER "B" FOR THE 24-HOUR ANTI-BLOCK

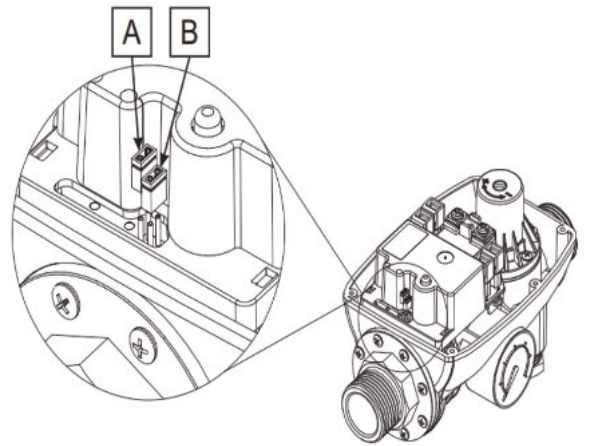







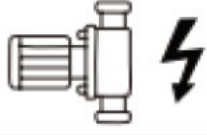

- 18) NOT SUITABLE FOR POOLS WITH PEOPLE IMMersed

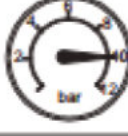

INSTALLATION

TECHNICAL DATA

	115-230 V 50/60 Hz
	1ph. - 12 A max.
	IP 65
	10 bar max.
	5 ÷ 55 °C.
	-10 ÷ 50 °C RH < 95 %
	-10 ÷ 70 °C RH < 95 %
	5 ÷ 45 °C RH < 85 %
 EN 60730	ACTION TYPE: 1.C POLLUTION DEGREE: III OVERVOLTAGE CATEGORY: III BALL PRESSURE TEST: 85°C